

### System Features

- High Reliability
- High Power Density
- Small Footprint
- ~99% Efficient
- Low Maintenance
- Environmentally Friendly
- Microprocessor Based
- Self-Diagnostics
- LCD Control Panel
- Fast Recharge-150 sec
- Soft-start UPS Integration
- Programmable Voltage Settings
- Programmable I/O Contacts
- Quiet Operation
- Long Useful Life
- Simple Installation
- No Special Wiring Required
- Compatibility Testing with multiple UPS brands

### Optional Features

- Front Panel DC Disconnect
- Parallel up to 2000-kW
- Monitoring Software
- Remote Notification (Email & Pager)
- Remote Monitoring (Network, and/or Modem)
- Ethernet
- SNMP & MODBUS Protocols
- Top/Bottom Entry
- N+1 Configurable
- Seismic Installation

## DC Flywheel Energy Storage System

### Ultimate Backup Power for UPS Systems

From industrial plants where maximum productivity is crucial, to the worldwide build-out of advanced data centers, power quality is essential to keep businesses online and fully operational. Active Power's CleanSource<sup>®</sup> DC battery-free technology is an integrated flywheel motor-generator that stores kinetic energy in its constantly spinning, quiet, low-

friction steel disc. Stored energy from the flywheel is instantly converted to electricity that bridges the power for critical loads during utility disturbances, and acts as an effective supplement or replacement for chemical energy storage with UPS systems. Compared to batteries, CleanSource DC dramatically reduces space requirements, temperature restrictions, replacement cycles and maintenance while improving UPS system reliability and operational integrity.



*Dual flywheel energy storage system pictured*



### Battery Hardening

- Extends Life of Batteries
- Battery Isolation
- Increases System Reliability
- Adaptive Voltage Settings
- No Special Connections

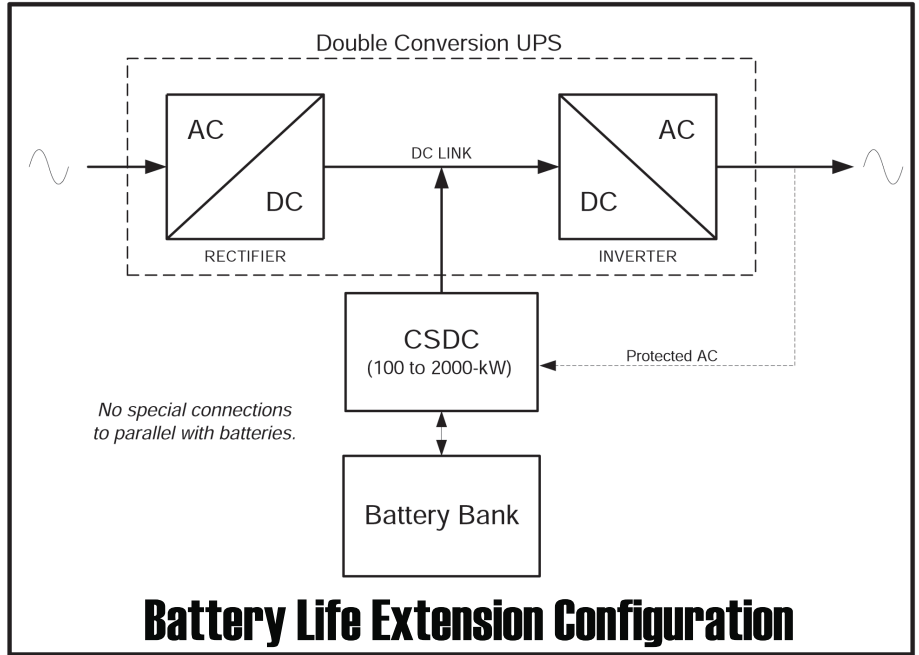

### Glitch Protection

- Battery-Free Operation
- No Generator Expense
- Industrial Process Protection
- Adaptive Voltage Settings
- Operational Range 0° to 104° F

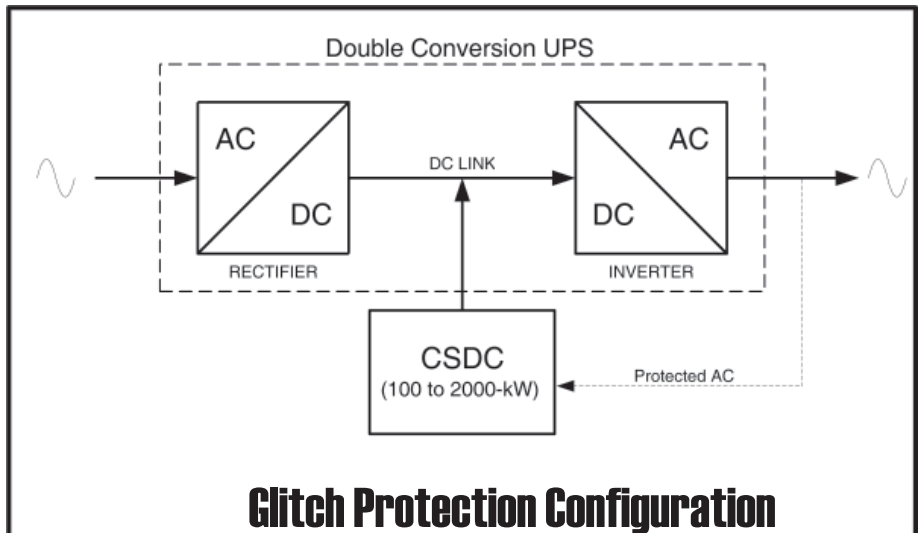

### Continuous Power

- Battery-Free Operation
- Small Foot-print
- Increases System Reliability
- Adaptive Voltage Settings
- Shields Genset from Step Loads

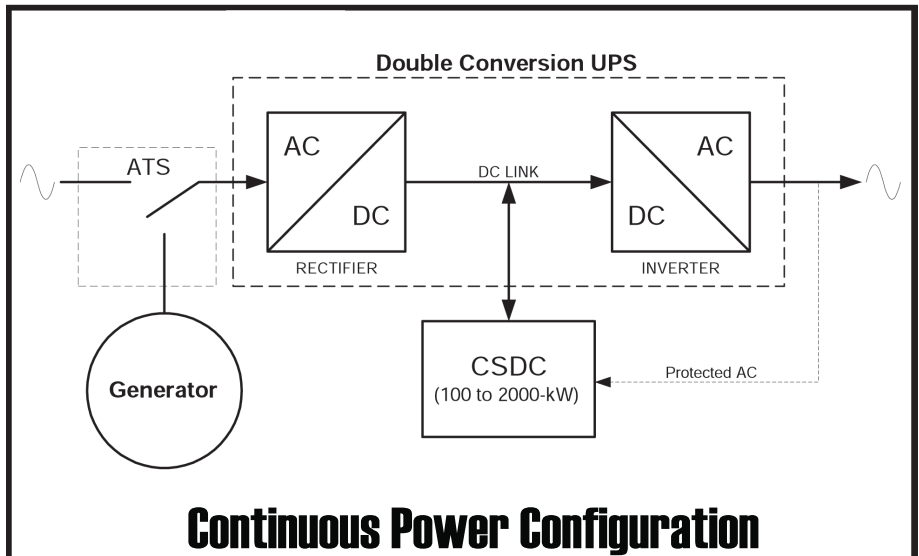

## Single Cabinet CSDC Solutions

KWB															
Model	40	60	80	100	120	140	160	180	200	250	300	350	400	425	500
CSDC-100	85.0	56.6	42.5	34.0	28.3										
CSDC-140	85.0	56.6	42.5	34.0	28.3	24.2									
CSDC-200	85.0	56.6	42.5	34.0	28.3	24.2	21.2	18.8	17.0						
CSDC-250	85.0	56.6	42.5	34.0	28.3	24.2	21.2	18.8	17.0	13.6					
CSDC-425	120.0	113.3	85.0	68.0	56.6	48.5	42.5	37.7	34.0	27.2	22.6	19.4	17.0	16.0	
CSDC-500	120.0	113.3	85.0	68.0	56.6	48.5	42.5	37.7	34.0	27.2	22.6	19.4	17.0	16.0	13.6

## Paralleled CSDC Solutions

KWB													
Model	500	525	550	600	650	700	750	800	1000	1250	1500	1750	2000
CSDC-750	20.4	19.4	18.5	17.0	15.6	14.5	13.6						
CSDC-1000	27.2	25.9	24.7	22.6	20.9	19.4	18.1	17.0	13.6				
CSDC-1250	34.0	32.3	30.9	28.3	26.1	24.2	22.6	21.2	17.0	13.6			
CSDC-1500	40.8	38.8	37.0	34.0	31.3	29.1	27.2	25.5	20.4	16.3	13.6		
CSDC-1750	47.6	45.3	43.2	39.6	36.6	34.0	31.7	29.7	23.8	19.0	15.8	13.6	
CSDC-2000	54.4	51.8	49.4	45.3	41.8	38.8	36.2	34.0	27.2	21.7	18.1	15.5	13.6

### Operational Characteristics Parameters

These four programmable parameters determine the operational characteristics of the CSDC. The parameters allow for customized installations to support any DC bus in the range of 360 to 600 VDC.

- 1. UPS Float Voltage:** Reference parameter.
- 2. Discharge Trigger Voltage:** DC voltage level at which the CSDC reacts to the falling DC link voltage level and goes into a discharge to support the load.
- 3. CSDC Discharge Voltage:** DC voltage level that is held constant throughout the CSDC discharge.
- 4. CSDC Recharge Threshold Voltage:** DC voltage level at which the CSDC will start to recharge. This parameter is set to ensure the CSDC does not recharge if the UPS is on battery power.

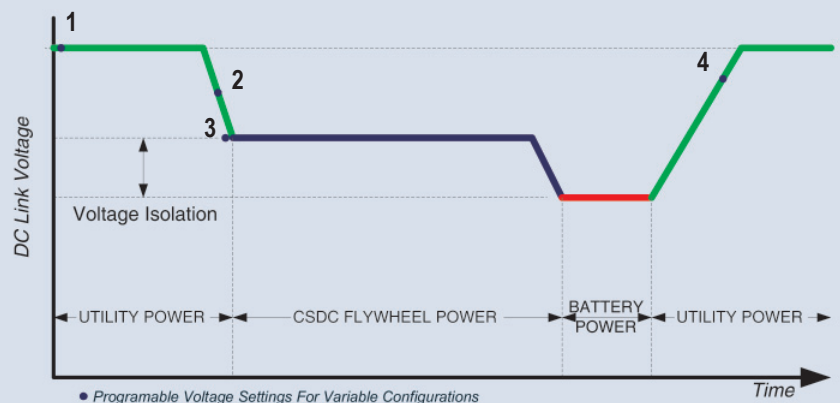

CleanSource DC Summary Specifications - Single Cabinet						
MODEL	CSDC-100	CSDC-140	CSDC-200	CSDC-250	CSDC-425	CSDC-500
<b>RATING</b>	100 kW	140 kW	200 kW	250 kW	425 kW	500 kW
<b>INPUT, DC</b>						
Float voltage	400 to 600 VDC					
Charging current	15 to 100 Amps per Flywheel					
Charging time from discharge	< 2.5 minutes per flywheel at maximum recharge current					
Charging time at start-up:	< 7.5 minutes per flywheel at maximum recharge current.					
Standby current, average	2 to 3 ADC			4 to 6 ADC		
<b>INPUT, AC</b>						
Auxiliary Voltage	120 / 240 / 480 VAC					
Current	28 / 14 / 7 Amps					
<b>OUTPUT</b>						
Adjustable discharge voltage	360 to 550 VDC					
Maximum rated output power	480 to 550 VDC <sup>(1)</sup>					
DC voltage regulation	± 1% steady state					
DC ripple	< 2%					
<b>ENVIRONMENTAL</b>						
Operating temperature range	0° C to 40° C					
Non-operating temperature range	0° C to 70° C					
Humidity	< 95% without condensation					
Operating altitude	4,000 ft with no derating					
Operating noise level	72 dB at 1 meter					
Heat dissipation	3.5 kW / 11,950 BTU			5.3 kW / 18,100 BTU		
<b>PHYSICAL DATA</b>						
Depth	34.0 in. (864 mm)					
Width	42 in (1067mm) (add 17inches bottom entry)			59.0 in (1499mm)		
Height	78 in (1981 mm)					
Weight	3,800 lbs (1724 kg)			5,800 lbs (2631 kg)		
Cable Access	Top standard, bottom with optional sidecar			Top or Bottom		

CleanSource DC Summary Specifications - Multiple Cabinets						
MODEL	CSDC-750	CSDC-1000	CSDC-1250	CSDC-1500	CSDC-1750	CSDC-2000
<b>RATING</b>	750 kW	1000 kW	1250 kW	1500 kW	1750 kW	2000 kW
<b>INPUT, DC</b>						
Float voltage	400 to 600 VDC					
Charging current	15 to 100 Amps per Flywheel					
Charging time from discharge	< 2.5 minutes per flywheel at maximum recharge current					
Charging time at start-up:	< 7.5 minutes per flywheel at maximum recharge current.					
Standby current, average	6-9 ADC	8-12 ADC	10-15 ADC	12-18 ADC	14-21 ADC	16-24 ADC
<b>INPUT, AC</b>						
Auxiliary Voltage	120 / 240 / 480 VAC					
Current	56 / 34 / 14 Amps		84 / 51/ 21 Amps		112 / 68 / 28 Amps	
<b>OUTPUT</b>						
Adjustable discharge voltage	360 to 550 VDC					
Maximum rated output power	480 to 550 VDC <sup>(1)</sup>					
DC voltage regulation	± 1% steady state					
DC ripple	< 2%					
<b>ENVIRONMENTAL</b>						
Operating temperature range	0° C to 40° C					
Non-operating temperature range	0° C to 70° C					
Humidity	< 95% without condensation					
Operating altitude	4,000 ft with no derating					
Operating noise level	72 dB at 1 meter					
Heat dissipation	8.8 kW 30,050 BTU	10.6 kW 36,200 BTU	14.1 kW 48,150 BTU	15.9 kW 54,300 BTU	19.4 kW 66,250 BTU	21.2 kW 72,400 BTU
<b>PHYSICAL DATA</b>						
Depth	34.0 in. (864 mm)					
Width	101 in (2,566mm)	118 in (2,998mm)	160 in (4,065mm)	177 in (4,497mm)	219 in (5,564mm)	236 in 5,996mm)
Height	78 in (1981 mm)					
Weight	9,600 lbs (4,355kg)	11,600 lbs (5,262 kg)	15,400 lbs (6,986 kg)	17,400 lbs (7,893 kg)	21,200 lbs (9,617 kg)	23,200 lbs (10,524 kg)

(1) power ratings decrease as a linear ratio per flywheel as discharge voltage setting is reduced from 480 to 360 VDC  
 (2) 250-kW building block systems require optional side car for bottom entry



2128 W. Braker Lane, BK12 • Austin, TX 78758 • Tel: 512-836-6464 • Fax: 512-836-4511  
 www.activepower.com • e-mail: sales@activepower.com

Every effort has been made to ensure the accuracy of this information, however Active Power assumes no responsibility, and disclaims all liability for damages resulting from use of this information or for any errors or omissions. All the trademarks designated herein are the sole property of Active Power. ©2004 Active Power, Inc. All rights reserved. Materials and specifications are subject to change without notice. The International System of Units (SI) is used in this publication.