

Exclusively from your Caterpillar® dealer

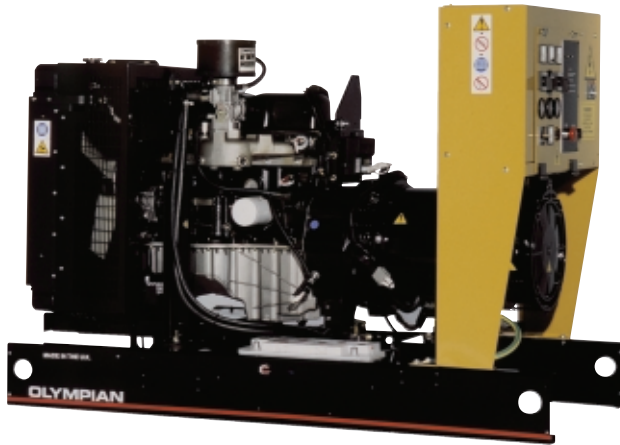

STANDBY 20-25 kW
PRIME 18-22.5 kW
60 Hz

Model	Standby — kW (kVA)		Prime — kW (kVA)	
	LP	Natural	LP	Natural
G20F3	20 (25)	20 (25)	18.0 (22.5)	18 (22.5)
G25F3	25 (31.3)	25 (31.3)	22.5 (28.1)	21 (26.3)
G20F3S	20 (20)	20 (20)	18 (18)	18 (18)
G25F3S	25 (25)	21 (21)	22.5 (22.5)	18 (18)

FEATURES

GENERATOR SET

- Complete system designed and built at ISO 9001 certified facilities
- Factory tested to design specifications at full load conditions

ENGINE

- Governor, Woodward electronic
- Electrical system, 12 VDC
- Cartridge type filters
- Natural gas fuel system, LP gas options available
- Gas shutoff valve, solenoid operated
- Gas pressure regulator
- Low oil pressure shutdown

GENERATOR

- Insulation system, class H
- Dip proof generator air intake (NEMA 2, IP23)
- Electrical design in accordance with BS5000 Part 99, IEC60034-1, EN61000-6, NEMA MG-1.33

AUTOMATIC VOLTAGE REGULATOR

- Voltage within $\pm 0.5\%$ 3 Phase and $\pm 1.0\%$ Single Phase at steady state from no load to full load
- Provides fast recovery from transient load changes

COOLING SYSTEM

- Radiator and cooling fan complete with protective guards
- Standard ambient temperatures up to 110° F (43° C)
- High coolant temperature shutdown
- Low coolant level shutdown
- Low coolant temperature alarm

MOUNTING ARRANGEMENT

- Heavy-duty fabricated steel base with lifting points
- Anti-vibration pads to ensure vibration isolation
- Battery, rack, and cables
- Coolant and lube oil drains piped to edge of base
- Complete OSHA guarding

- Stub-up pipe ready for connection to silencer pipework
- Weather protective enclosures are available
- Fuel line terminated at base with NPT connections

CIRCUIT BREAKER

- 3-pole with solid neutral, UL/CSA listed
- NEMA 1 steel enclosure, vibration isolated
- Electrical stub-up area directly below circuit breaker

CONTROL SYSTEM

- 2001K Autostart control panel
- Vibration isolated NEMA 1 enclosure with hinged access door
- Engine and generator instrumentation
- Volts adjust potentiometer
- Safety shutdown and alarm indicators
- Audible alarm for all faults
- Volt-free contact for common alarm
- AD/DC wiring with multi-pin connectors for system flexibility

EQUIPMENT FINISH

- All electroplated hardware
- Anticorrosive protection prior to painting
- High gloss polyurethane paint for durability and scuff resistance

QUALITY STANDARDS

- BS4999, BS5000, BS5514, IEC60034, EN61000-6, NEMA MG-1-33, ISO8528, NFPA 110 (with optional equipment)

DOCUMENTATION

- Operation and maintenance manuals provided
- Wiring diagrams included

WARRANTY

- All equipment carries full manufacturer's warranty

STANDBY 20 - 25 kW
PRIME 18 - 23 kW
60 Hz

OLYMPIAN™

Exclusively from your Caterpillar® dealer

OPTIONAL EQUIPMENT*

ENCLOSURE

- Weatherproof enclosure (includes internal silencer system)
- Sound attenuated enclosure (includes internal silencer system)

SILENCER SYSTEM — OPEN UNIT

- Level 1 silencer
- Level 2 silencer
- Level 3 silencer
- Mounting kit
- Through-wall installation kit

ENGINE

- Battery heater
- Lube oil sump heater, 100/120V

SKIDBASE ACCESSORIES

- Seismic vibration isolators (Zone 4)

GENERATOR

- Anti-condensation heater
- Generator upgrade 1 size (G20F3, G25F3)

COOLING SYSTEM

- Coolant heater, 110/120V
- Radiator transition flange

CONTROL SYSTEM

- Circuit breaker auxiliary contacts, volt free
- Circuit breaker shunt trip (100 amp and above)
- Static battery charger
- UL listed static battery chargers

FUEL SYSTEM

- LP gas (vapor)
- LP gas (liquid)

MISCELLANEOUS ACCESSORIES

- Toolkit
- Additional operator's manual pack
- CSA certification
- French Language labels

EXTENDED SERVICE CONTRACTS

- Extended Service Coverage available

TESTING

- Special factory test available

*Some options may not be available on all models. Not all options are listed.

GENERATOR SET DIMENSIONS AND WEIGHTS

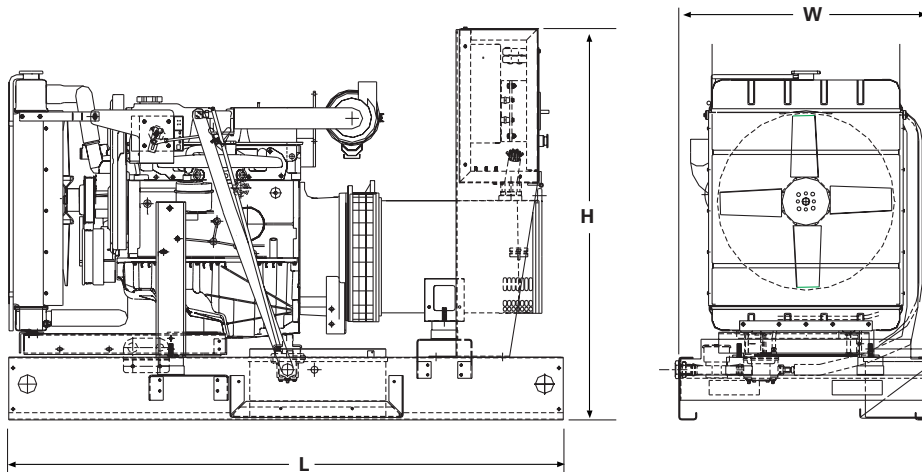

Model	Length in (mm)	Width in (mm)	Height in (mm)	Weight lbs (kg)**
G20F3	60.9 (1548)	28.0 (710)	74.9 (1902)	1047 (475)
G25F3	60.9 (1548)	28.0 (710)	74.9 (1902)	1085 (492)
G20F3S	60.9 (1548)	28.0 (710)	74.9 (1902)	1085 (492)
G25F3S	60.9 (1548)	28.0 (710)	74.9 (1902)	1113 (505)

NOTE: General configuration not to be used for installation. See specific dimensional drawings for detail.

**Includes oil and coolant

STANDBY 25 / 25 kW
PRIME 22.5 / 22.5 kW
60 Hz

OLYMPIAN™

Exclusively from your Caterpillar® dealer

G25F3 (3-Phase)

Materials and specifications are subject to change without notice.

Generator Set Technical Data — 1800 rpm/60 Hz		LP Gas		Natural Gas	
		Standby	Prime	Standby	Prime
Power Rating	kW (kVA)	25.0 (31.3)	22.5 (28.1)	25.0 (31.3)	22.5 (28.1)
Lubricating System Type: Full Pressure Oil Filter: Spin-On, Full Flow Oil Type Required: API CF-4 Total Oil Capacity Oil Pan	U.S. gal (L) U.S. gal (L)	1.1 (4.3) 1.0 (3.8)	1.1 (4.3) 1.0 (3.8)	1.1 (4.3) 1.0 (3.8)	1.1 (4.3) 1.0 (3.8)
Fuel System Generator Set Fuel Consumption 100% Load 75% Load 50% Load	Cfh (m³/hr) Cfh (m³/hr) Cfh (m³/hr)	138 (3.9) 104 (2.9) 70 (2.0)	127 (3.6) 96 (2.7) 64 (1.8)	345 (9.8) 259 (7.3) 174 (4.9)	294 (8.3) 222 (6.3) 149 (4.2)
Engine Electrical System Ignition System: Electronic, Distributorless Voltage/Ground: 12/Negative Battery Charging Generator Ampere Rating	Amps	95	95	95	95
Cooling System Water Pump Type: Centrifugal Radiator System Capacity Incl. Engine Maximum Coolant Static Head Coolant Flow Rate Minimum Temperature to Engine Temperature Rise Across Engine Heat Rejected to Coolant at Rated Power Total Heat Radiated to Room at Rated Power Radiator Fan Load	U.S. gal (L) Ft H ₂ O (m H ₂ O) U.S. gal/min (L/min) °F (°C) °F (°C) Btu/min (kW) Btu/min (kW) Hp (kW)	3.3 (12.3) 10 (3.1) 17.7 (67) 169 (76) 15 (8) 1487 (26.2) 784 (13.8) 0.5 (0.35)	3.3 (12.3) 10 (3.1) 17.7 (67) 169 (76) 15 (8) 1369 (24.0) 722 (12.7) 0.5 (0.35)	3.3 (12.3) 10 (3.1) 17.7 (67) 169 (76) 15 (8) 1346 (24.0) 710 (12.5) 0.5 (0.35)	3.3 (12.3) 10 (3.1) 17.7 (67) 169 (76) 15 (8) 1145 (20.1) 604 (10.6) 0.5 (0.35)
Air Requirements Combustion Air Flow Maximum Air Cleaner Restriction Radiator Cooling Air (zero restriction) Generator Cooling Air Allowable Air Flow Restriction (After radiator) Cooling Airflow (@ rated speed) Rate with restriction	Cfm (m³/min) In H ₂ O (kPa) Cfm (m³/min) Cfm (m³/min) In H ₂ O (kPa) Cfm (m³/min)	79.5 (2.2) 10 (2.5) 2755 (78) 382 (10.8) 0.5 (0.125) 1906 (54)	73.1 (2.0) 10 (2.5) 2755 (78) 382 (10.8) 0.5 (0.125) 1906 (54)	79.5 (2.2) 10 (2.5) 2755 (78) 382 (10.8) 0.5 (0.125) 1906 (54)	67.5 (1.8) 10 (2.5) 2755 (78) 382 (10.8) 0.5 (0.125) 1906 (54)
Exhaust System Maximum Allowable Backpressure Exhaust Flow at Rated kW Exhaust Temperature at Rated kW — Dry Exhaust	In Hg (kPa) Cfm (m³/min) °F (°C)	2.7 (9.1) 252 (7.1) 1213 (656)	2.7 (9.1) 223 (6.3) 1186 (641)	2.7 (9.1) 252 (7.1) 1213 (656)	2.7 (9.1) 223 (6.3) 1186 (641)
Generator Set Noise Rating* (Without Attenuation) at 3 ft (1 m)	dB(A)	85.4	84.9	85.4	84.9

Generator Technical Data	277/480V	120/240V 120/208V		
Motor Starting Capability: (kVA) Self Excited	69	51		
Full Load Efficiencies: Standby Prime	89.7 90.0	88.9 89.4		
Reactances (per unit): X_d X'_d X''_d Reactances shown are applicable to the LPG standby rating X_q X''_q X_2 X_0	1.91 0.10 0.052 0.95 0.074 0.064 0.005	2.54 0.14 0.069 1.26 0.099 0.085 0.007		
Time Constants:	t'_d 25 ms	t''_d 2.5 ms	t'_{do} 452 ms	t_a 4 ms

* dB(A) levels are for guidance only