



## THERMOCOUPLE MODULE

### GENERAL DESCRIPTION

The Caterpillar Thermocouple module serves to provide expandable engine and generator temperature monitoring capability for your package generator set.

The Caterpillar Service Tool ET is used to configure the Thermocouple module, while all monitored temperatures and alarm conditions are viewable on the EMCP 3 control panel. Configuration capability includes the desired operating temperature setpoints for high and low temperature settings.

The Thermocouple module can be Package or Remote mounted (up to 800 feet) and features rugged packaging and watertight Deutsch IPD connectors.

These features all add to the sense of value and dependability that comes with your purchase of Caterpillar products.

### OPERATOR INTERFACE

- All Thermocouple monitored parameters are available for viewing with EMCP 3.3 Controller.

### FEATURES/BENEFITS

- Customer programmable protective functions, available as alarm and shutdown, protects against high and low temperature conditions.
- J1939 communication network eliminates the need for multiple switches, meters, transducers, relays, and sending units, which translates to less wiring and fewer opportunities for mechanical failures.
- Remote customer communications are supported by MODBUS protocol using RS-485 (via EMCP 3.3) which easily interfaces with existing plant systems and equipment.
- Set points are stored in nonvolatile memory, preventing loss during a power outage.

### COMMUNICATION

- Single, standard 40-pin connector.
- J1939 #2 (Accessory Data Link).
- MODBUS RS-485 (Customer Communication) via the EMCP 3.3 controller.

### GENERAL SPECIFICATIONS

#### TECHNICAL DATA

- Reads up to 20 Type J or K thermocouple inputs.
- Burden is limited to less than 200 mA. Inrush does not exceed 800 mA.
- Isolation voltage is 1500 VAC (RMS) or 2550V for 1 sec.
- System throughput has all 20 channels scanned in 2 seconds (100 mSec./channel).
- Three way isolation is provided for the CAN line, inputs and power supply.

## GENERAL SPECIFICATIONS (CONT'D)

### ENVIRONMENTAL

- Operating temperature range of  $-40^{\circ}\text{C}$  to  $85^{\circ}\text{C}$  ( $-40^{\circ}\text{F}$  to  $+185^{\circ}\text{F}$ ) – for ambient temperatures exceeding  $85^{\circ}\text{C}$  ( $185^{\circ}\text{F}$ ), the temperature scanner may deviate in accuracy an additional  $\pm 1^{\circ}\text{C}$ .
- Storable temperature range is  $-50^{\circ}\text{C}$  to  $+120^{\circ}\text{C}$  ( $-238^{\circ}\text{F}$  to  $+248^{\circ}\text{F}$ ).
- Protected against 95% humidity non-condensing,  $30^{\circ}\text{C}$  to  $60^{\circ}\text{C}$  ( $86^{\circ}\text{F}$  to  $140^{\circ}\text{F}$ ).
- Overall drift with temperature is  $150\text{ ppm}/^{\circ}\text{C}$  of span (maximum). Cold junction compensation is provided.

### MOUNTING

- Encapsulated in a rugged aluminum housing with watertight connectors (IP65 rating).
- Suitable for moist, high shock and vibration environments.
- Designed to meet relevant European standards for EMI/RFI/Immunity without the use of external filtering.

### MONITORING

- One byte parameters have a resolution of  $1^{\circ}\text{C}/\text{bit}$  and a range of  $-40^{\circ}\text{C}$  to  $210^{\circ}\text{C}$  ( $-40^{\circ}\text{F}$  to  $+478^{\circ}\text{F}$ )
- Two byte parameters have resolution of  $0.03125^{\circ}\text{C}/\text{bit}$  and a range of  $-273^{\circ}\text{C}$  to  $1735^{\circ}\text{C}$  ( $-459^{\circ}\text{F}$  to  $+3155^{\circ}\text{F}$ )
- Common mode rejection is  $-80\text{ db}$  @  $5\text{V p-p}$  ( $50\text{-}60\text{ Hz}$ ).
- Common mode input range is  $\pm 4\text{ V}$  minimum.

### NETWORK COMMUNICATIONS INTERFACE

- Retains current date and time relative to synchronization every 24 hours (or upon boot up) with equipment system time via an explicit command from the EMCP 3.3. (or CAT ET) – synchronization time is accurate to within 1 sec.
- Monitored parameters and setpoints are customizable to customer specification.
- Module is fully functional during configuration and communications.
- Module operates normally with loss of communication link, retaining configured values and error codes in non-volatile memory.
- Parameter values and diagnostic error codes are retained when the modules are de-energized.
- For J1939 compliance, all modules comply with the applicable portions of the following:
  - SAE J1939-21, July 1998, Data Link Layer
  - SAE J1939-71, January 2002, Application Layer
  - SAE J1939-73, May 2000, Application Layer – Diagnostic
  - SAE J1939-81, July 1997, Network Management.

## AVAILABLE TEMPERATURE INPUTS

The Thermocouple Module is configured to accept inputs for the following temperatures, to be displayed at the EMCP 3.3 controller in either Fahrenheit or Celsius

- Air Inlet Temperature
- Generator Bearing Temperatures (1-2)
- Generator Winding Temperature (1-3)
- Ambient Air Temperature
- Auxiliary Temperature (1-2)
- Battery Temperature (1-2)
- Engine Auxiliary Coolant Temperature
- Engine Coolant Temperature
- Engine Intercooler Temperature
- Engine Oil Temperature (1-2)
- Exhaust Gas Port Temperature (1-20)
- Exhaust Gas Temperature
- Left Manifold Exhaust Gas Temperature
- Right Manifold Exhaust Gas Temperature
- Fuel Temperature
- Intake Manifold Temperature (1-6)
- Engine Bearing Temperature (1-11)
- Turbo Oil Temperature
- Turbocharger Compressor Inlet Temperature (1-4)
- Turbocharger Turbine Inlet Temperature (1-4)
- Turbocharger Turbine Outlet Temperature (1-4)

### THERMOCOUPLE MODULE DIAGNOSTICS

The Thermocouple Module is configured to display the following diagnostics for each of the listed inputs, to be displayed at the EMCP 3.3 controller:

- Thermocouple Input Sensor Open Circuit
- Thermocouple Input Sensor Short Circuit
- Thermocouple Input High Temperature Warning
- Thermocouple Input High Temperature Shutdown
- Thermocouple Input Low Temperature Warning

### THERMOCOUPLE MODULE LOG ENTRIES

The Thermocouple Module is capable of storing up to twenty diagnostic log entries, viewable from the EMCP 3.3 controller. Each log entry includes the following information:

- Time of Last Occurrence
- Date of Last Occurrence
- Time of First Occurrence
- Date of First Occurrence
- Engine Run Hours – First Occurrence
- Engine Run Hours – Last Occurrence
- Number of Occurrences

## TYPICAL CONNECTIONS — POWER AND CAN BUS

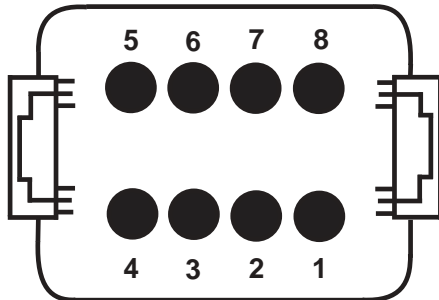

FRONT VIEW  
MODULE MOUNTED CONNECTOR  
DEUTSCH P/N: DT13-08PA

- 1 = PWR+      5 = SHIELD
- 2 = CAN-H    6,7,8 = NOT USED
- 3 = CAN-L
- 4 = PWR-

## TYPICAL CONNECTIONS — THERMOCOUPLE MODULE

*Type J or K*

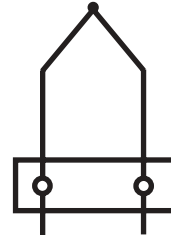

T/C MODULE - PIN OUT

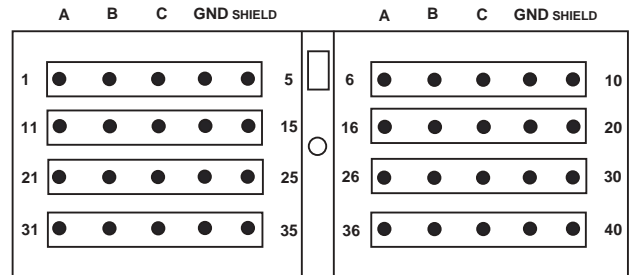

FRONT VIEW OF  
MODULE MOUNTED CONNECTOR

## DIMENSIONS

FRONT VIEW  
(8-Pin Connector)

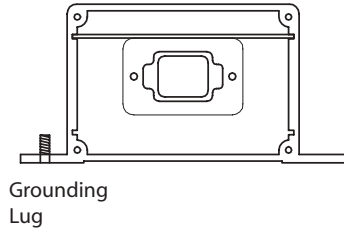

BACK VIEW  
(40-Pin Connector)

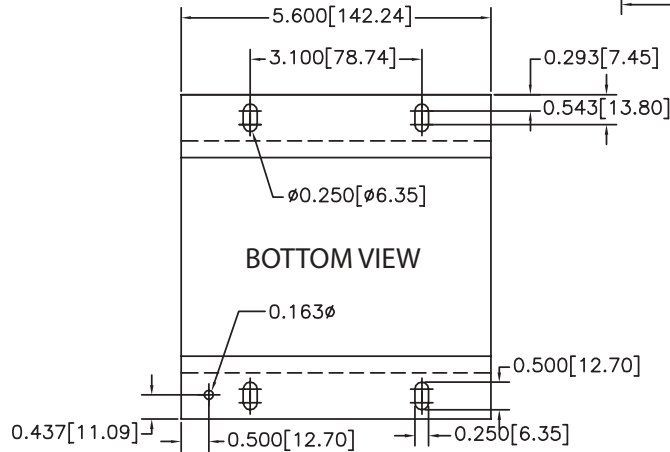
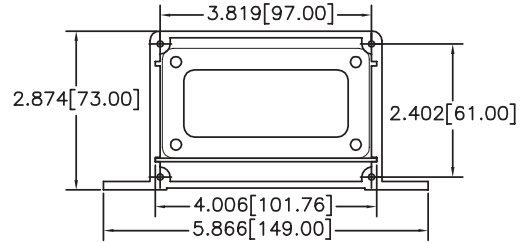

Connectors excluded from overall dimensions.

Dimensions: inches [mm]